

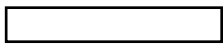

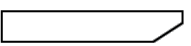

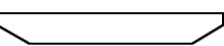

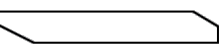

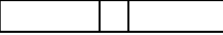

Übersicht Messer

Hersteller: _____ Gerät: _____ Typ: _____

Ersatzteil- Nr. _____ Referenz-Nr. _____

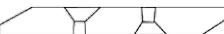
Grundmaterial		Bitte Typ ankreuzen!	
Typ 1 ohne Schneidkante 	<input type="checkbox"/>	Typ 2 eine Schneidkante 	<input type="checkbox"/>
		Typ 3 doppelte Schneidkante 	<input type="checkbox"/>
		Typ 4 parallele Schneidkante 	<input type="checkbox"/>
Typ 5 gerade Schneidkante 	<input type="checkbox"/>		

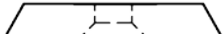
Bohrungstyp		Bitte Typ ankreuzen!	
Typ 11 	<input type="checkbox"/>	Typ 12 	<input type="checkbox"/>
		Typ 13 	<input type="checkbox"/>
		Typ 14 	<input type="checkbox"/>
Typ 15 	<input type="checkbox"/>	Typ 16 	<input type="checkbox"/>
		Typ 17 	<input type="checkbox"/>
		Typ 18 	<input type="checkbox"/>
Typ 19 	<input type="checkbox"/>		

Abmaße		in mm	
A Breite		G Teilung	
B Stärke		H Abstand Bohrung	
C Länge Gesamt		J Abstand Bohrung	
F Bohrung		K Endmaß	
L Schraube		M Bohrung Abstand (zweireihig)	
N Endmaß			

