

Magnet plates

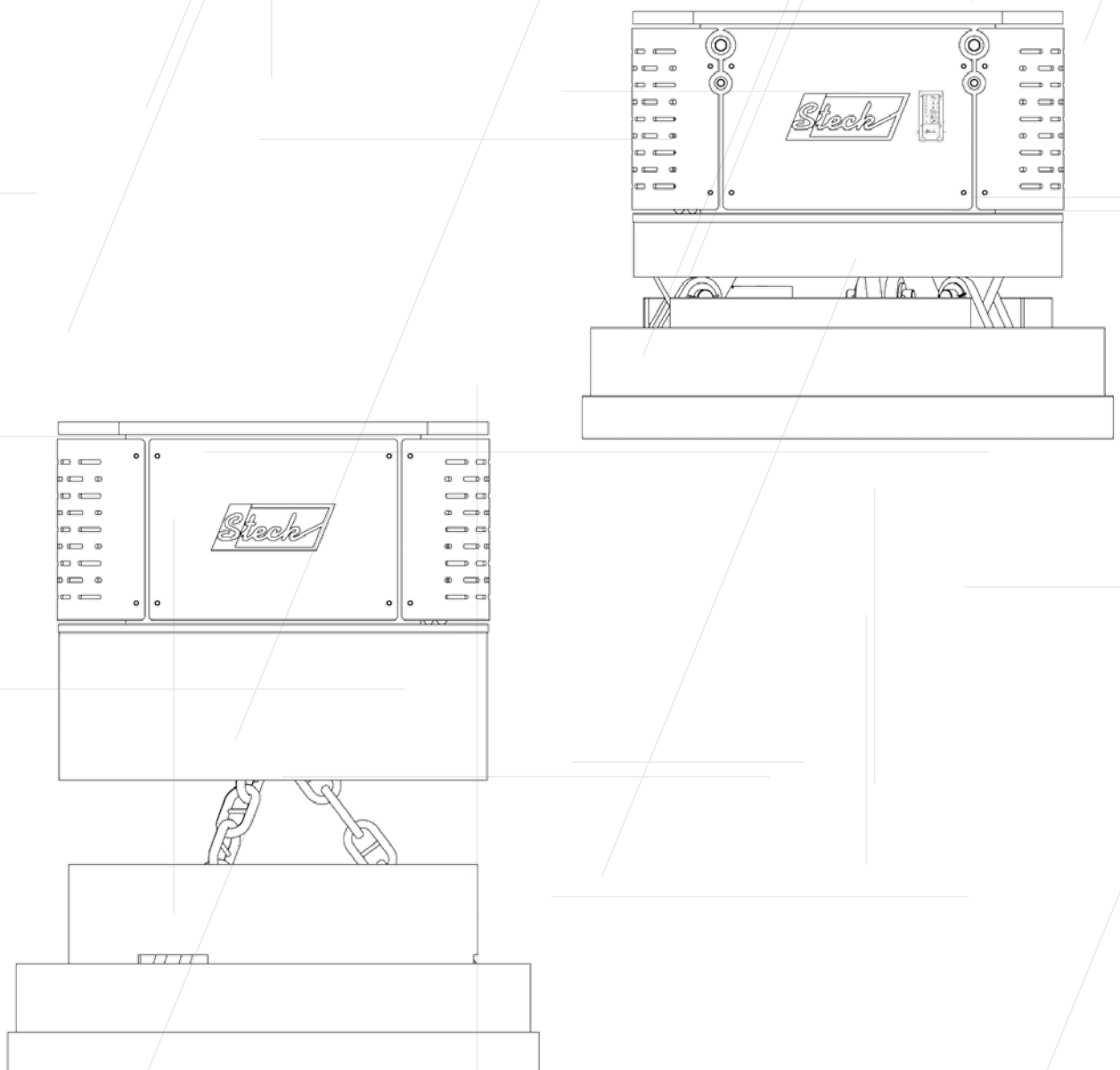

Magnet plates

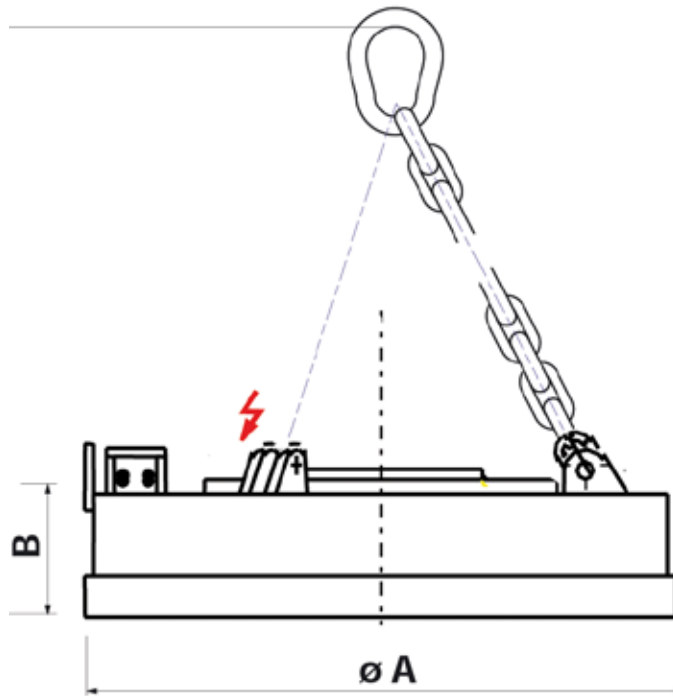

¹ According to VDE 0580. Defined in 5 hours from changing labor (50%), at ambient temperature of 20°C.

Technical details	MP 2	MP 4
weight (kg)	195	265
dimension A (mm)	550	750
dimension B (mm)	200	225
mains voltage (Vgs)	24	220
magnet power (kW)	0,6	3
with air gap Ø /300 ¹ Tensile strength (kg)	2.600	5.500
load capacity ¹ slab blocks (kg)	1.300	2.700
load capacity ¹ bullets capacity (kg)	450	950
load capacity ¹ iron pig (kg)	70	105
load capacity ¹ Scrap 3A 2,2÷2, 5 T/m3 (kg)	60	80
load capacity ¹ Scrap 24 1,9÷2,0 T/m3 (kg)	50	70
load capacity ¹ Scrap 40 0,8÷1, 0 T/m3 (kg)	40	40
Lifting magnets	M3	M4

Due to special construction of magnet plate a better depth effect is achieved. Magnet plate is made of wear-resistant material which lead to longer lifetime.

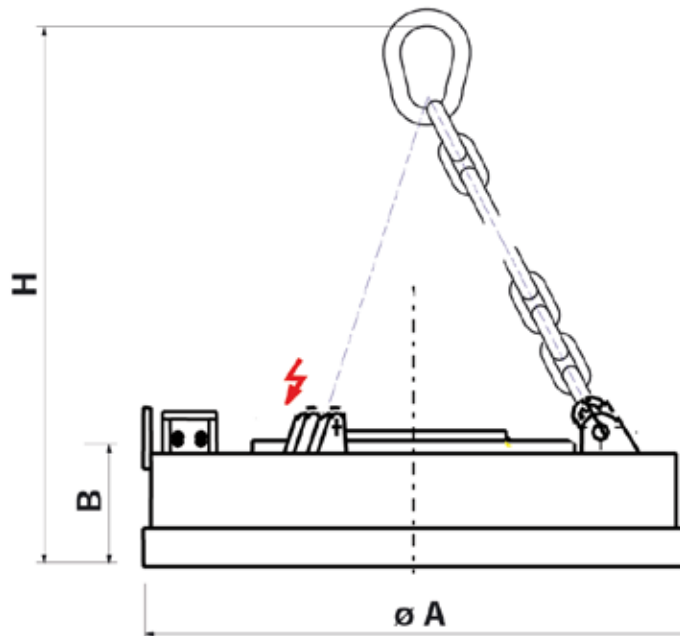

¹ According to VDE 0580. Defined in 5 hours from changing labor (50%), at ambient temperature of 20°C.

Technical details	MP 6	MP 8	MP 9	MP 11	MP 14	MP 19
weight (kg)	550	780	890	1.100	1.400	1.850
dimension A (mm)	860	1.060	1.140	1.250	1.450	1.660
dimension B (mm)	280	280	280	305	285	290
dimension H (mm)	975	975	975	1.000	1.000	1.000
Ø magnet (mm)	860	1.060	1.140	1.250	1.450	1.660
mains voltage (Vgs)	220	220	220	220	220	220
magnet power (kW)	4,4	5,5	7	9	10	15
with air gap Ø /300 ¹ Tensile strength (kg)	8.200	11.500	13.000	15.000	18.000	21.000
load capacity ¹ slab blocks (kg)	4.100	5.750	6.500	7.500	9.000	10.500
load capacity ¹ bullets capacity (kg)	1.700	2.600	3.000	3.500	4.200	5.000
load capacity ¹ iron pig (kg)	200	280	320	410	580	640
load capacity ¹ Scrap 3A 2,2÷2, 5 T/m ³ (kg)	170	255	290	370	530	580
load capacity ¹ Scrap 24 1,9÷2,0 T/m ³ (kg)	160	240	280	360	510	550
load capacity ¹ Scrap 40 0,8÷1, 0 T/m ³ (kg)	80	120	140	190	240	270
Lifting magnets	M8	M14	M15	M16	M20	M22

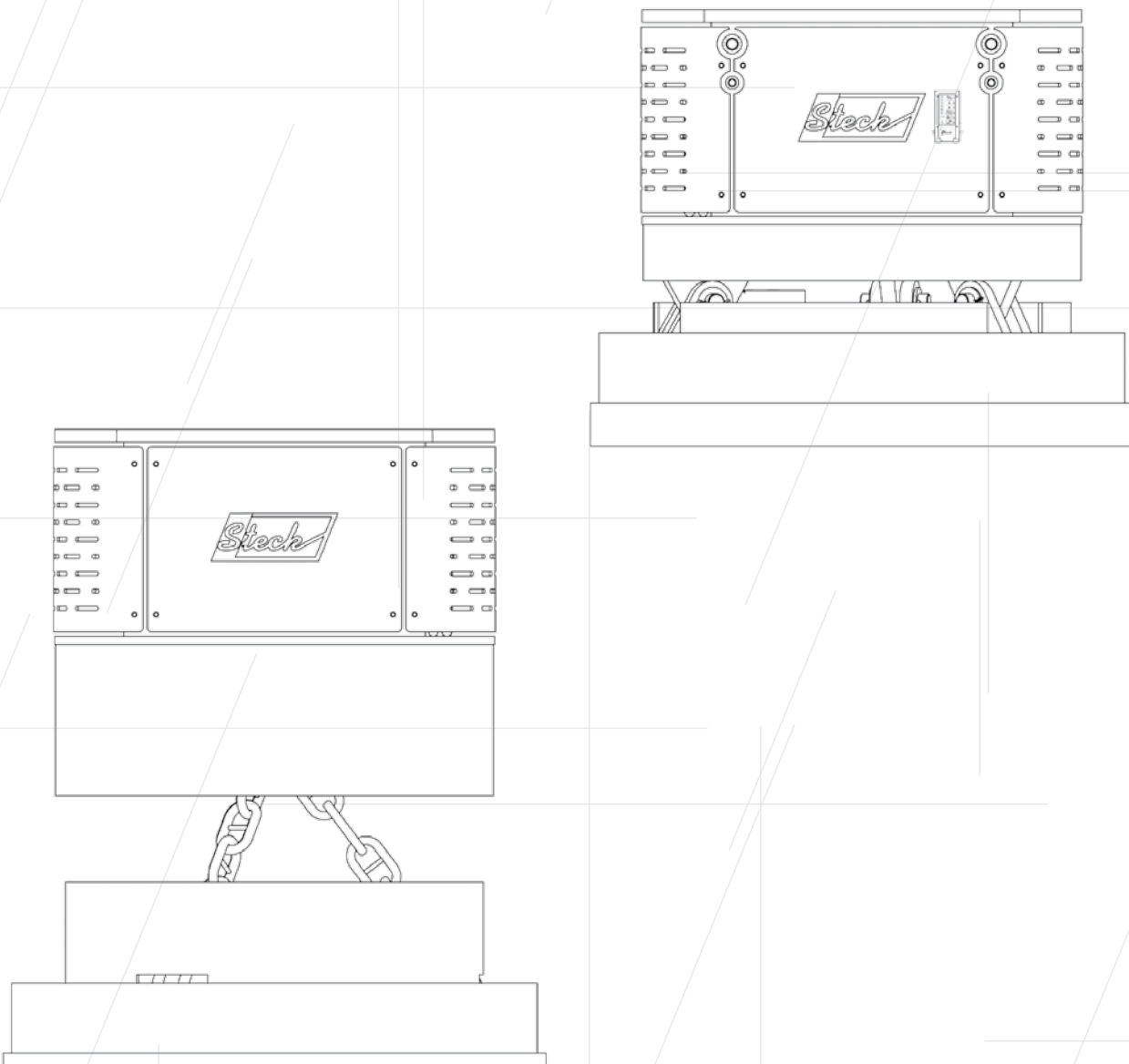

Steck Abbruchgeräte GmbH
Hauptstr. 20
D- 89192 Rammingen
Germany
place of jurisdiction: Ulm/Donau HRB 726131
VAT- ID No.: DE275269830
phone +49 (0) 7345 9123 - 0
fax +49 (0) 7345 9123 - 20
mail info@steck.de
internet www.steck.de

your contact person::

A large rectangular area with a dashed border, intended for the contact person's name and details.