

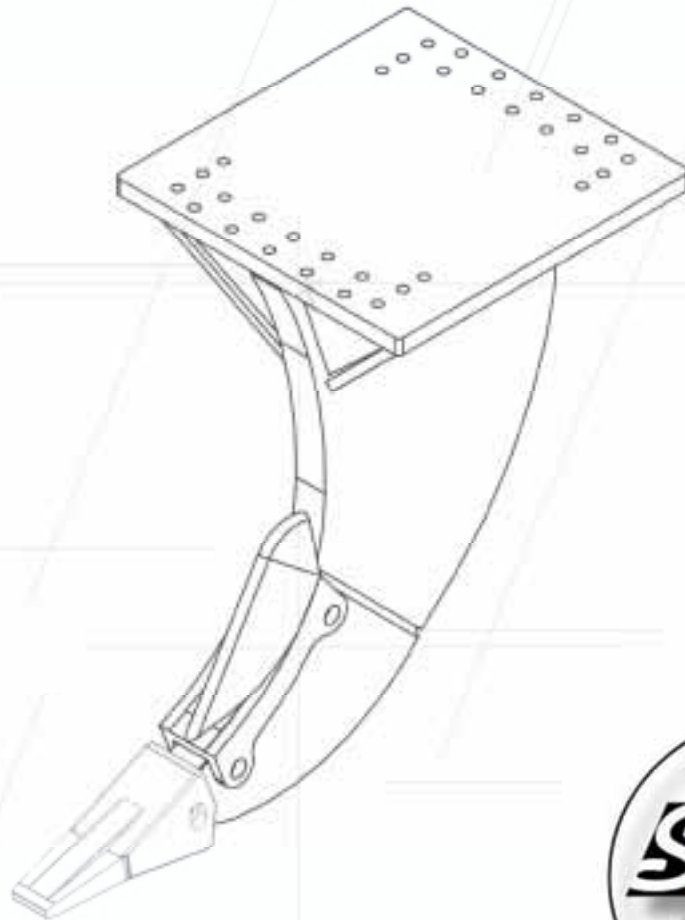

Ripper tooth



Ripper tooth

Standard- Version (S)



Technical details

	R002-MS01	R002-MS03
operating weight (t)	0,5 - 2,2	1,5 - 5,0
weight (kg)	31	41
mounting plate	MS01	MS03
B (mm)	329	400
C (mm)	225	225
D (mm)	20	20
H (mm)	362	362
teeth (CAT)	J200	J200

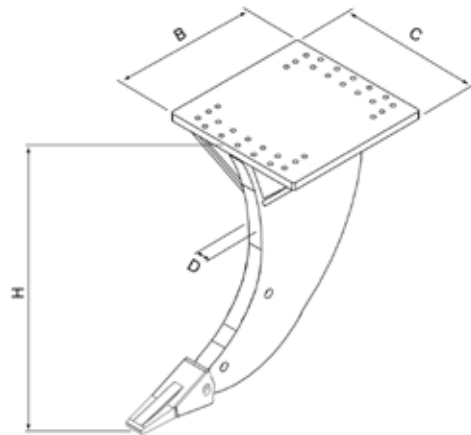

Technical details

	R01S	R02S	R03S	R04S	R06S	R07S
operating weight (t)	5 - 9	7 - 15	15 - 21	21 - 32	27 - 42	37 - 66
weight without head plate (kg)	62	230	305	390	620	670
B (mm)	460	630	630	630	725	965
C (mm)	400	725	725	725	900	1.050
D (mm)	30	40	45	50	70	80
H (mm)	500	690	710	790	1.100	1.100
teeth (CAT)	J200	J300	J350	J460	J550	J700

HD- Version (HD)



Technical details	R03HD	R04HD	R05HD
operating weight (t)	16 - 21	20 - 26	21 - 32
weight without head plate (kg)	320	390	410
B (mm)	700	700	700
C (mm)	550	600	680
D (mm)	75	75	75
H (mm)	750	850	950
teeth	EAN10342	EAN10342	EAN10342

Technical details	R06HD	R07HD	R09HD
operating weight (t)	27 - 42	37 - 66	65 - 90
weight without head plate (kg)	480	520	840
B (mm)	700	800	1.150
C (mm)	710	900	1.100
D (mm)	75 / 70	75 / 80	110
H (mm)	1.100	1.250	1.350
teeth	EAN10342	EAN10342	6Y9473

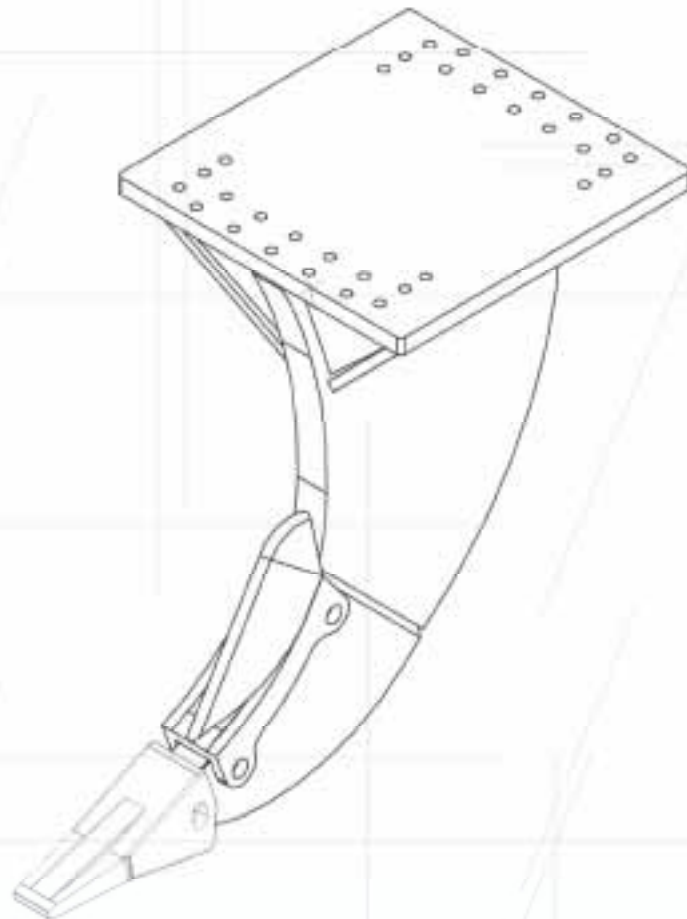

Steck Abbruchgeräte GmbH
Hauptstr. 20
D- 89192 Rammingen

place of jurisdiction: Ulm/Donau HRB 726131
VAT- ID No.: DE275269830
phone +49 (0) 7345 9123 - 0
fax +49 (0) 7345 9123 - 20
mail info@steck.de
internet www.steck.de

your contact person:

A large dashed rectangular box intended for the contact person's name and details.